

SURFACE FINISH	
As Machined	
Acid	
Glass Bead	
Orbital Sand	
Powder Coat	
Zinc Plate	
Anodise	
Polished	
Scotch Brite	
DeBurr	

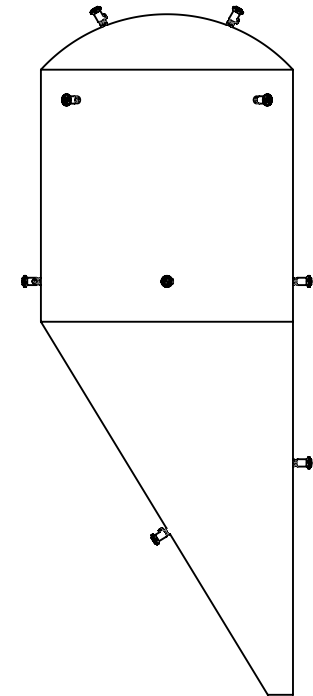
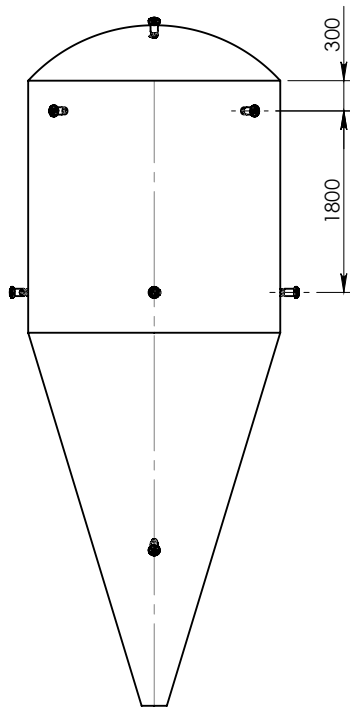
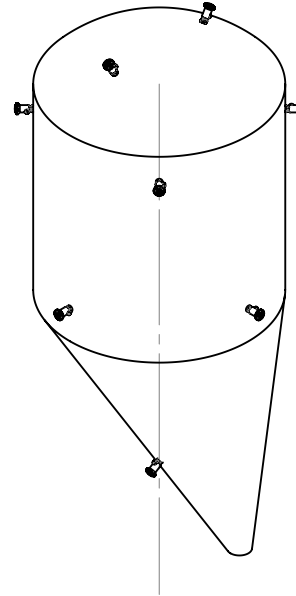
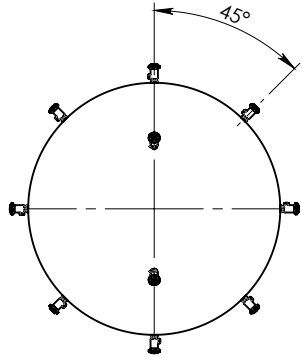

rml ENGINEERING LTD.
 66 NORRIS AVENUE,
 HAMILTON, NEW ZEALAND.
 P.O.BOX 20414, TE RAPA.
 p +64 7 849 3215, f +64 7 849 6157
 www.mlengineering.com

COPYRIGHT
 © 2010 rml ENGINEERING LTD.
 THIS DRAWING MAY NOT
 BE REPRODUCED OR
 TRANSMITTED WITHOUT
 PRIOR PERMISSION

TOLERANCES

NO DECIMAL PLACE	=0	+0.2 -0.2
ONE DECIMAL PLACE	=0.0	+0.1 -0.1
FABRICATION	=0	+1.0 -1.0

ALL DIMENSIONS ARE IN MILLIMETERS

Spray Drier Nozzle Positioning

MATERIAL:				DRAWING No.		REV.
				Part No		
				PRINTED: 21/07/2010		SHEET
				DESIGN: Yves Dubler		141
				DRAWN: AS ABOVE		
REV	BY	DATE	MODIFICATIONS			